***BioMEMS Case Study: Microdevices for
PCR***

Joel Voldman*

Massachusetts Institute of Technology

***with thanks to SDS**

Outline

- > **What is hard about BioMEMS**
- > **BioMEMS success stories**
- > **DNA amplification and PCR**
- > **Two designs**
 - **A static PCR thermocycler**
 - **A flow-thru design**
 - **Comparison**
- > **Design evolution of static approach**
- > **Conclusions**

BioMEMS

> Applications of microsystems to bioscience

- Neural probes
- Capillary electrophoresis
- Drug delivery
- Cellular engineering
- Tissue engineering

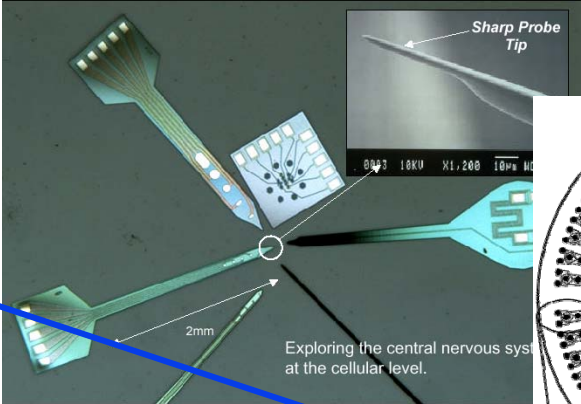

Univ. Michigan

Courtesy of Kensall D. Wise. Used with permission.

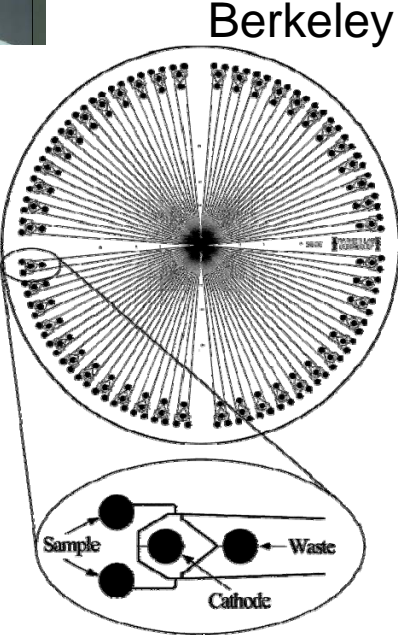

Courtesy of Richard A. Mathies. Used with permission.

Image removed due to copyright restrictions.

Image removed due to copyright restrictions.

Image removed due to copyright restrictions.

What is hard about BioMEMS

- > **The biological system is poorly defined**
 - We fundamentally understand physics
 - We DON'T fundamentally understand biology
 - Thus, only part of system can be truly predictively designed
- > **“Intrinsic” biological limitations can dictate system performance**
 - Protein-protein interaction kinetics
 - Polymerase error rates
- > **The materials (and thus processes) are often NOT silicon (and thus harder)**
 - We must move away from the most established fabrication technologies

BioMEMS success stories

> Depending on the definition,
there are very few

Image removed due to copyright restrictions.

PCB-mountable pressure sensor for medical applications.

> **Commercial successes**

- **Blood pressure sensors**
 - » **Low-cost “widget” allows devices to be disposable**
- **Affymetrix DNA microarrays**
 - » **Vastly decreases time and cost for analyzing nucleic acids**
 - » **But these are not really bioMEMS**

BioMEMS success stories

> Depending on the definition, there are very few

> Commercial successes

- Blood pressure sensors
 - » Low-cost “widget” allows devices to be disposable
- Affymetrix DNA microarrays
 - » Vastly decreases time and cost for analyzing nucleic acids
 - » But these are not really bioMEMS

Courtesy of Affymetrix, Inc. Used with permission.

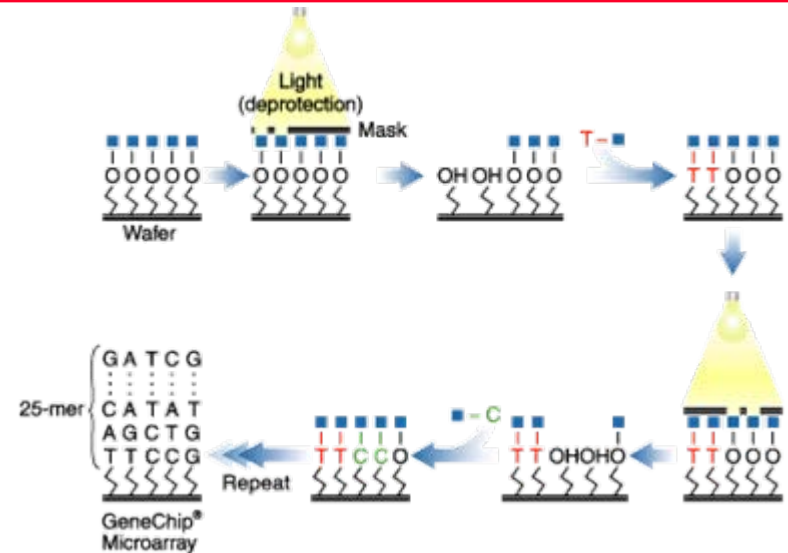

Courtesy of Affymetrix, Inc. Used with permission.

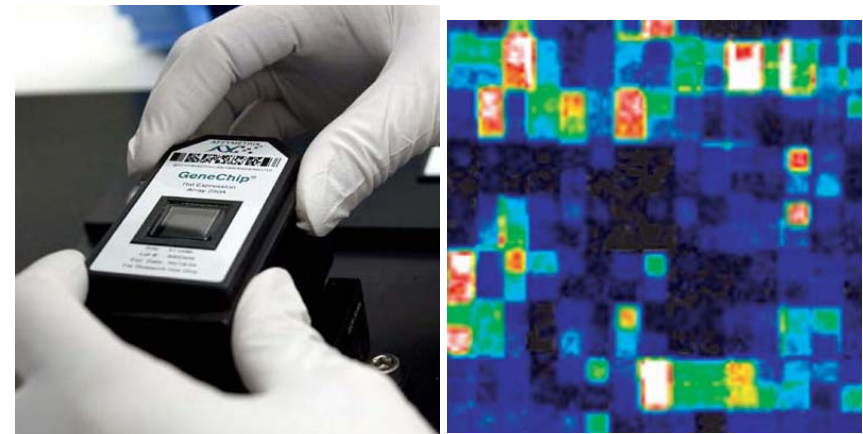

Courtesy of Affymetrix, Inc. Used with permission.

BioMEMS success stories

> In the commercial sector,
there has been lots of hype

- Success is uncertain

Image removed due to copyright restrictions.
Lab-on-a-chip is about the size of a U. S. dime.

> Caliper/Aclara

- Lab-on-a-chip

> I-stat

- Portable blood analyzer
- Uses ion-selective electrodes, conductivity, etc. to measure salts, glucose, etc.
- Introduced ~1997
- Purchased by Abbott

Image removed due to copyright restrictions.

BioMEMS success stories

- > Away from commercial sector and into basic science, more successes arise
- > Success can be defined as having impact on the target audience

- > **Ken Wise's neural probes**

- CMOS + bulk micromachining
- Puts op-amp right near neural recording sites → amplifies and buffers weak ($\sim\mu\text{V}$) signals
- These are being used by neuroscientists in actual experiments

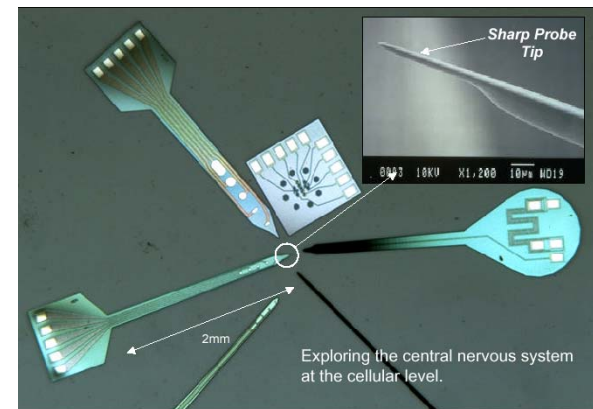

Univ. Michigan

Courtesy of Kensall D. Wise.
Used with permission.

Outline

- > **What is hard about BioMEMS**
- > **BioMEMS success stories**
- > **DNA amplification and PCR**
- > **Two designs**
 - **A static PCR thermocycler**
 - **A flow-thru design**
 - **Comparison**
- > **Design evolution of static approach**
- > **Conclusions**

DNA (deoxyribonucleic acid)

- > DNA contains the genetic information (genotype) that determines phenotype (i.e., you)
- > It consists of a two antiparallel helical strands
 - Read 5' to 3'
 - A sugar-phosphate backbone
 - Specific bases (A, C, G, T) that contain genetic code
- > This code determines the sequence of amino acids in proteins

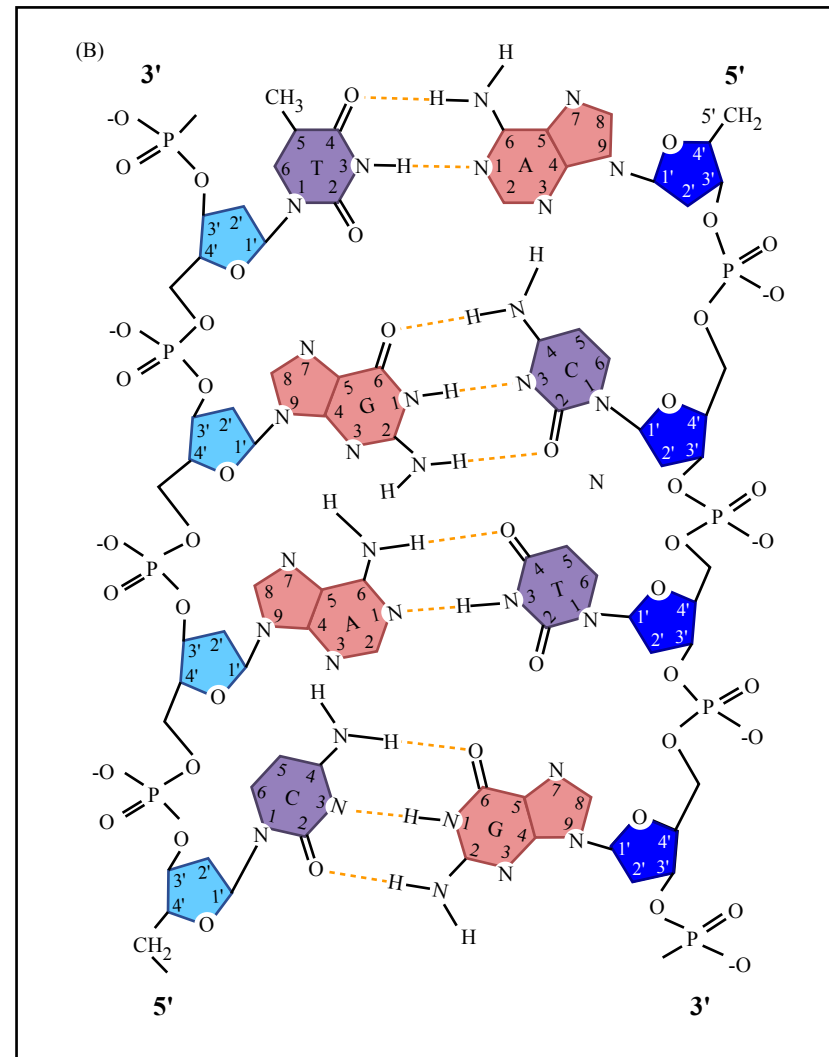

Lodish, MCB Image by MIT OpenCourseWare.

DNA Amplification

- > **The bases pair specifically**
 - **A with T**
 - **C with G**

- > **Specific enzymes (DNA polymerases) can add complementary nucleotides to an existing template + primer**
 - **This is done *in vivo* in DNA replication**

- > **Was capitalized *in vitro* in polymerase chain reaction (PCR)**
 - **Invented in 1985, Nobel Prize in 1993**

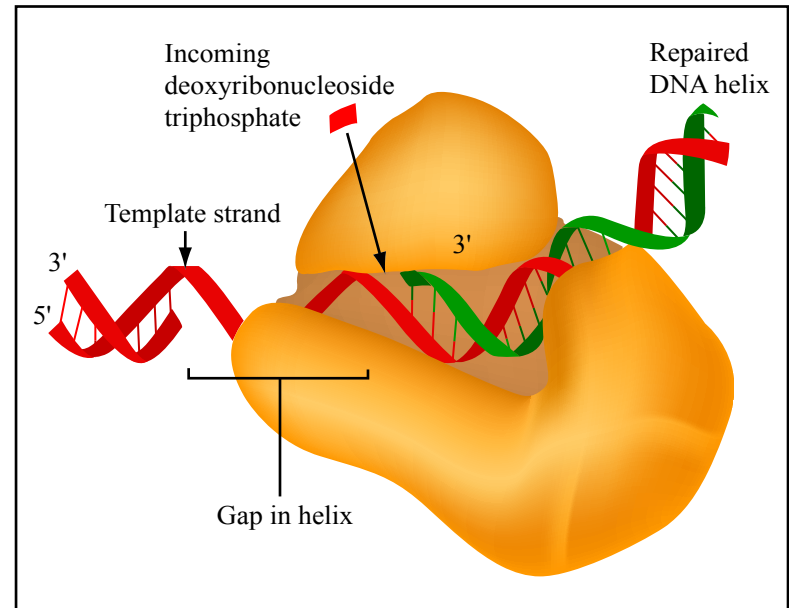

Image by MIT OpenCourseWare.

Alberts, MBC

Polymerase chain reaction (PCR)

- > Specifically amplify DNA starting from 1 double-stranded copy

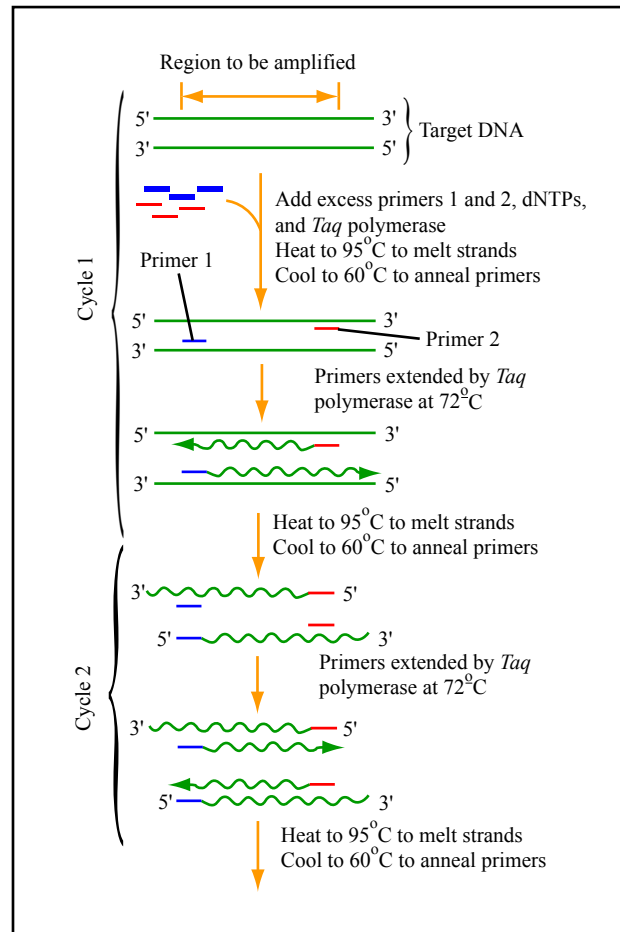

Image by MIT OpenCourseWare.

Lodish, MCB

Polymerase chain reaction (PCR)

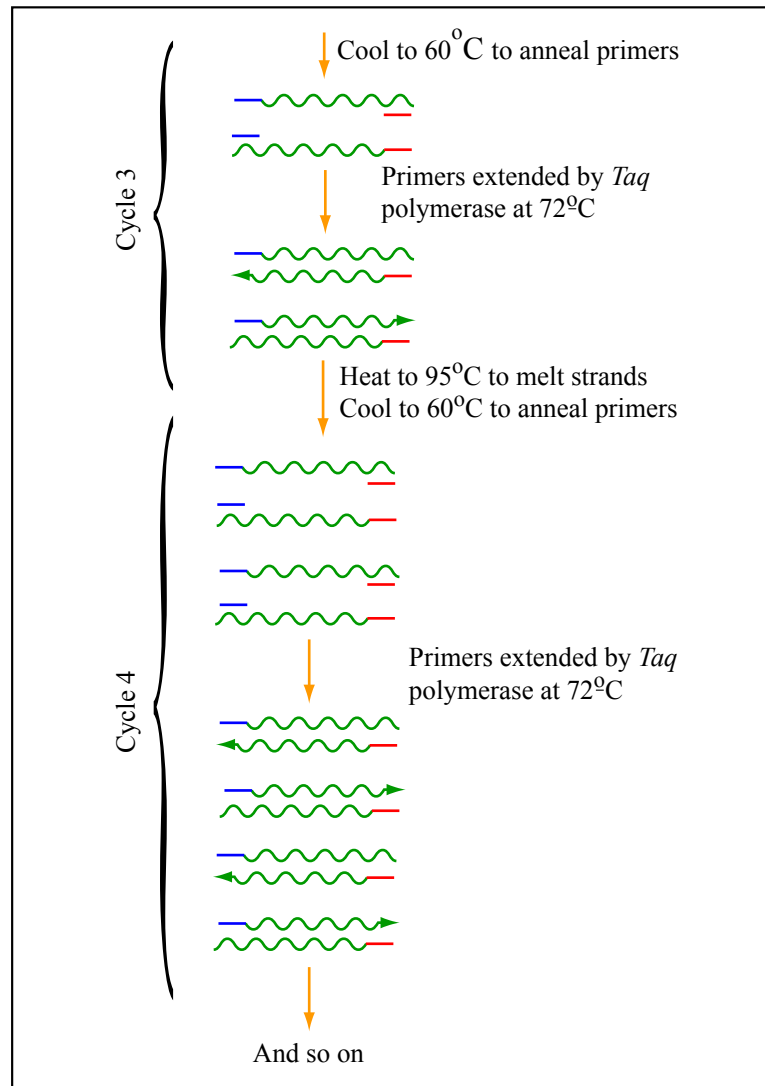

Image by MIT OpenCourseWare.

Lodish, MCB

PCR

- > **Key technological improvement was use of polymerase that could withstand high temperatures**
 - **Isolated from *Thermus aquaticus* (*Taq*)**
 - **Don't have to add new polymerase at each step**
- > **The device is a simple thermocycler**
- > **Allows amplification and detection of small quantities of DNA**

Image removed due to copyright restrictions.
PCR machine by MJ Research.

PCR cycles

- > **Taq extension rate ~60 nt/sec**
- > **PCR products are typically a few hundred bases**
 - **Need ~5 sec for extension**
 - **Plus time for diffusion**
- > **Typical protocols**
 - **~25-35 cycles at 1-3 min/cycle**
 - **~30 cycles → 75 minutes**

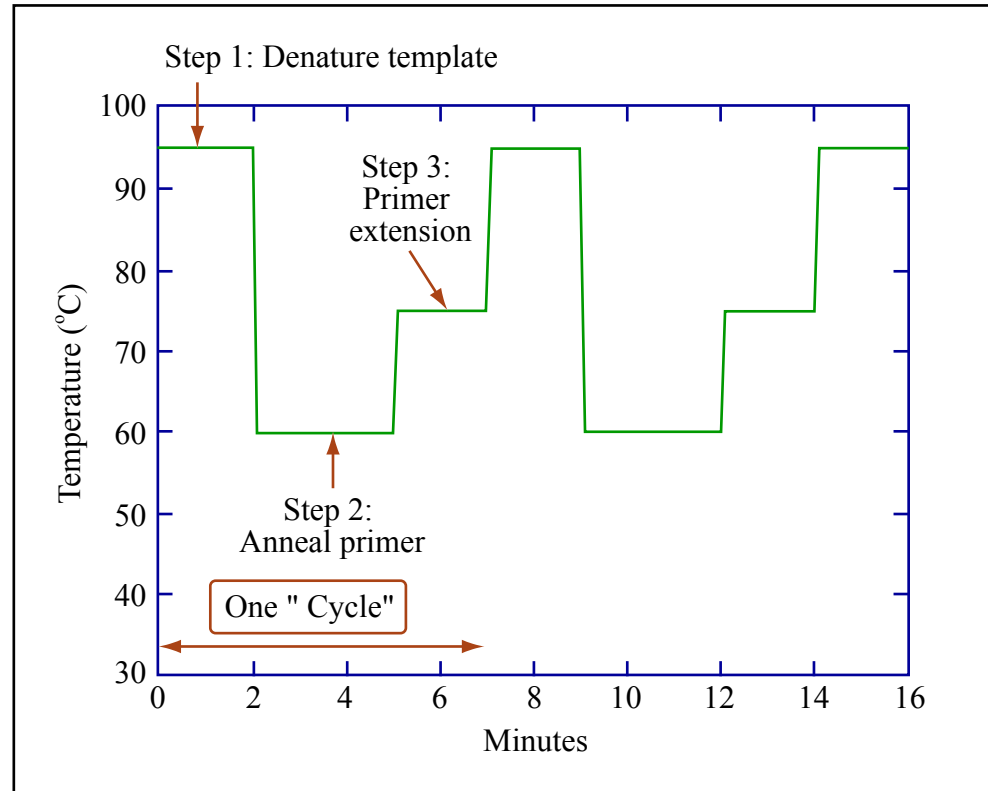

Image by MIT OpenCourseWare.

PCR

- > **Cycle time is dominated by ramp times due to thermal inertia**
 - **Usually much longer than kinetically needed**
- > **Transient and steady-state temperature uniformity limits cycle time & specificity**

Property	Spec
Temp range	5-105 °C
Set-point accuracy	±0.25 °C
Temperature uniformity	±0.4 °C within 30 sec
Heating/cooling rate	~ 3 °C/sec
Sample volume	50 µl
Number of samples	96
Power required	850 W

BioRad DNA Engine

Outline

- > **What is hard about BioMEMS**
- > **BioMEMS success stories**
- > **DNA amplification and PCR**
- > **Two designs**
 - **A static PCR thermocycler**
 - **A flow-thru design**
 - **Comparison**
- > **Design evolution of static approach**
- > **Conclusions**

Two approaches to miniaturization

- > **Decrease size of chamber**
 - Vary temperature in time
- > **Use a flow-thru approach**
 - Vary temperature in space (and therefore time)
- > **In both cases, the device is a thermal MEMS device and the key is to reduce thermal response times**

Batch PCR

> First reported by Northrup *et al.*
in 1993

- Essentially a miniaturized thermal cycler

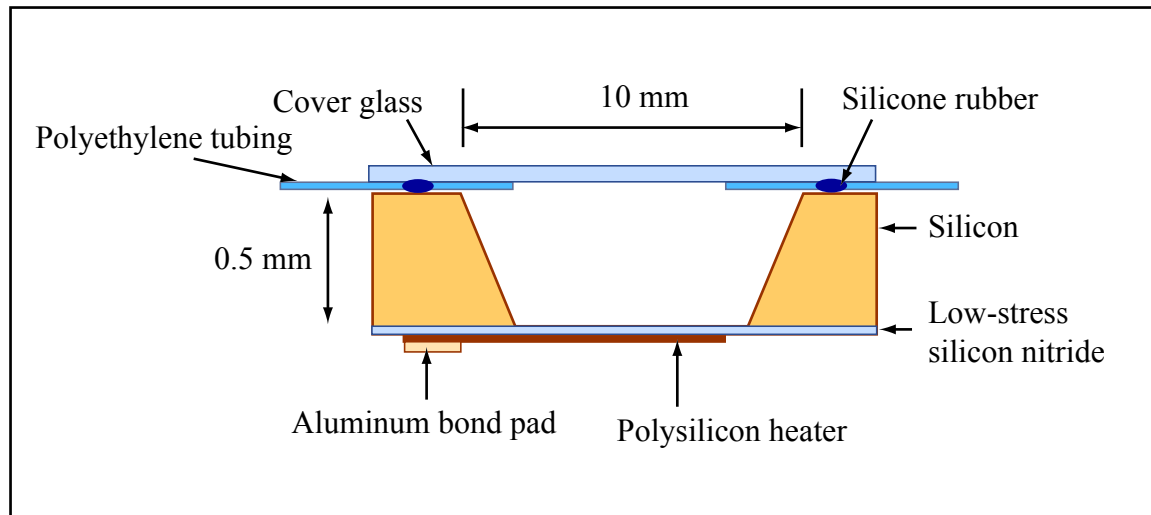

Image by MIT OpenCourseWare.

Adapted from Northrup, M. A., M. T. Ching, R. M. White, and R. T. Watson. "DNA Amplification with a Microfabricated Reaction Chamber." In *Transducers '93: the 7th International Conference on Solid-State Sensors and Actuators: digest of technical papers: June 7-10, 1993, PACIFICO, Yokohama, Japan*. Japan: Hiroyuki Fujita, 1993, p. 924-926. ISBN: 9784990024727.

Northrup et al., Transducers '93, p924

Batch PCR

- > Daniel *et al.* improved thermal isolation

Silicon nitride web (1 μm) Reaction chamber

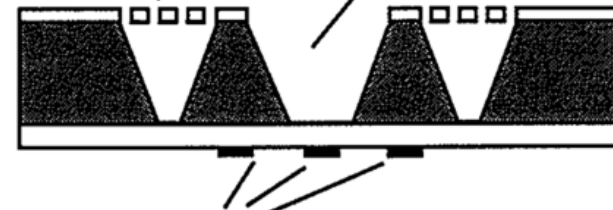

Platinum resistors on 3 μm silicon nitride membrane

Courtesy of Elsevier, Inc., <http://www.sciencedirect.com>. Used with permission.
Figure 5 on p. 84 in: Daniel, J. H., S. Iqbal, R. B. Millington, D. F. Moore, C. R. Lowe, D. L. Leslie, M. A. Lee, and M. J. Pearce. "Silicon Microchambers for DNA Amplification." *Sensors and Actuators A, Physical* 71, nos. 1-2 (November 1998): 81-88.

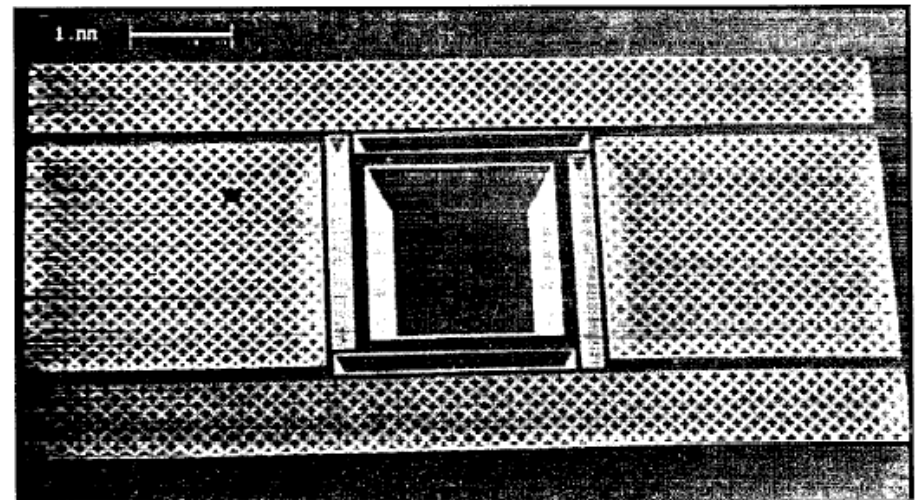
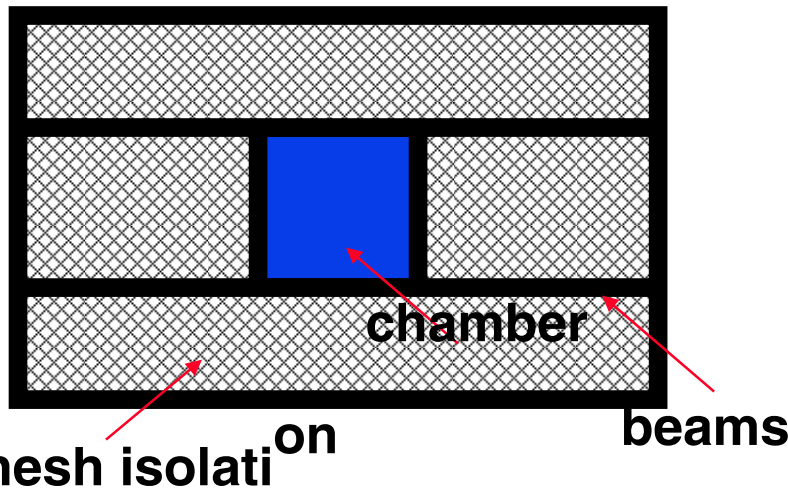

Courtesy of Elsevier, Inc., <http://www.sciencedirect.com>. Used with permission.
Figure 3 on p. 83 in: Daniel, J. H., S. Iqbal, R. B. Millington, D. F. Moore, C. R. Lowe, D. L. Leslie, M. A. Lee, and M. J. Pearce. "Silicon Microchambers for DNA Amplification." *Sensors and Actuators A, Physical* 71, nos. 1-2 (November 1998): 81-88.

Continuous-flow PCR

> Developed by Kopp *et al.* in 1998

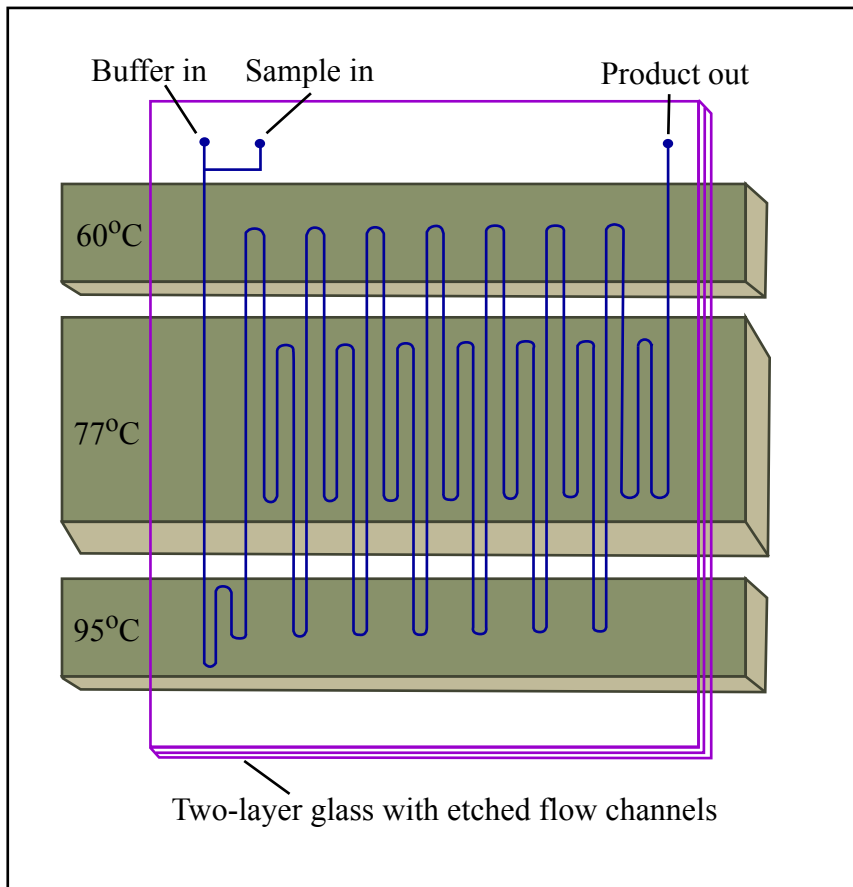

Image by MIT OpenCourseWare.

Adapted from Figure 1 on p. 1046 in Kopp, M. U., A. J. de Mello, and A. Manz. "Chemical Amplification: Continuous-flow PCR on a Chip." *Science, New Series* 280, no. 5366 (May 15, 1998): 1046-1048.

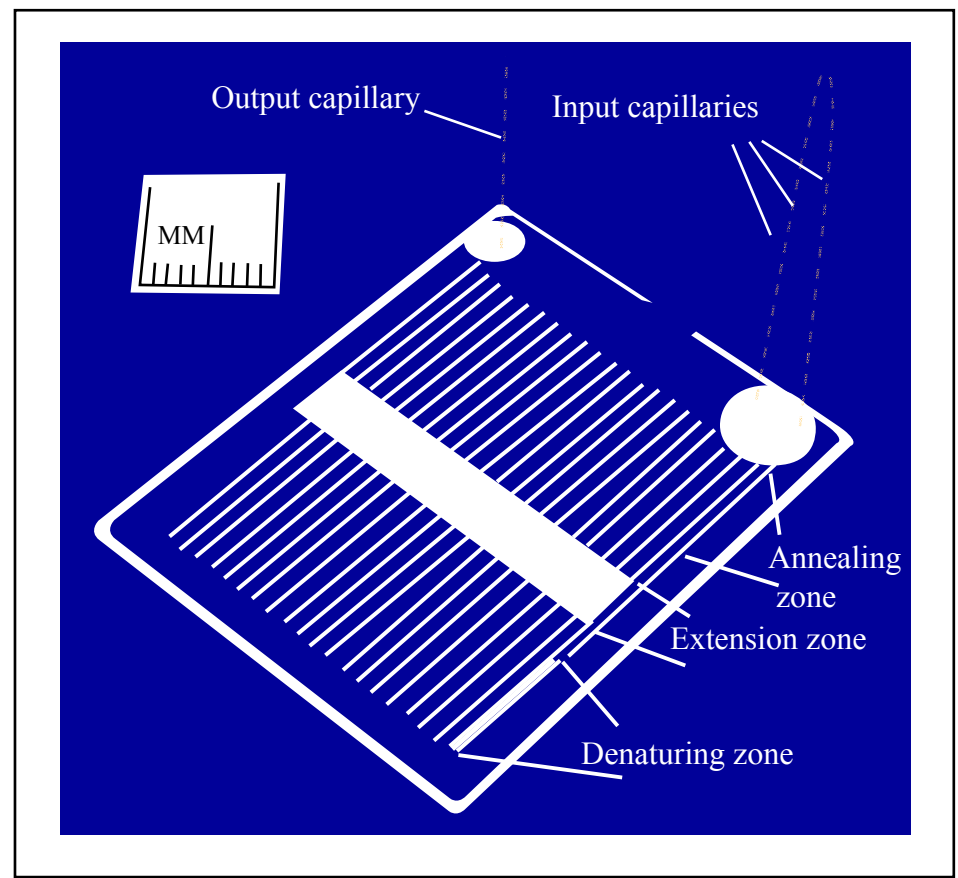

Image by MIT OpenCourseWare.

Adapted from Kopp, M. U., A. J. de Mello, and A. Manz. "Chemical Amplification: Continuous-flow PCR on a Chip." *Science, New Series* 280, no. 5366 (May 15, 1998): 1046-1048.

Batch PCR

> Daniel reactor

- SiN mesh structure, undercut with KOH
 - » Made hydrophobic to keep water in chamber during loading
- Platinum heater resistors heat up beams
- Two temperature sensing resistors
 - » One on beams for feedback control
 - » One on membrane to sense “liquid” temp
- Use oil drop on top of liquid to prevent evaporation

Courtesy of Elsevier, Inc., <http://www.sciencedirect.com>.
Used with permission. Figure 3 on p. 83 in: Daniel, J. H., S. Iqbal, R. B. Millington, D. F. Moore, C. R. Lowe, D. L. Leslie, M. A. Lee, and M. J. Pearce. "Silicon Microchambers for DNA Amplification." *Sensors and Actuators A, Physical* 71, nos. 1-2 (November 1998): 81-88.

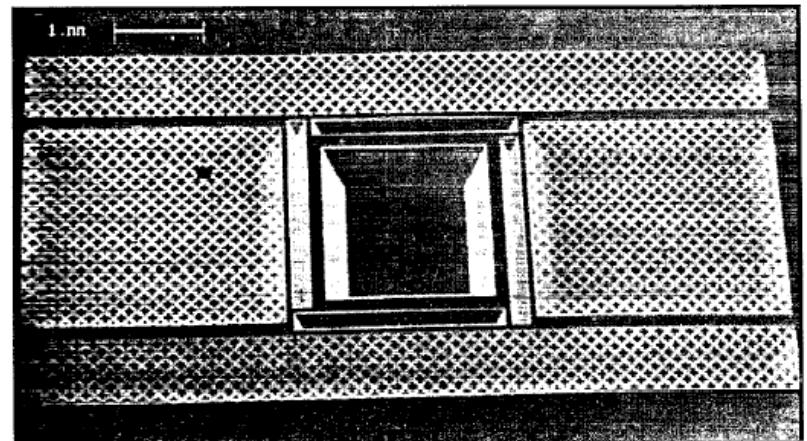

Thermal modeling – batch system

- > Three steps
- > Model chamber
- > Model beams
- > Combine the two, with heating at beams

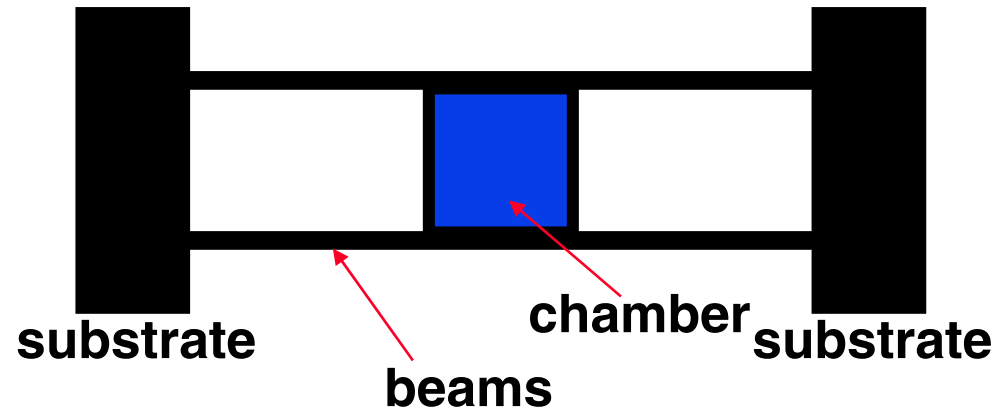

Thermal modeling – batch system

- > Chamber model
- > Assume rectangular cross-section
- > Assume dominant heat loss through beams
 - 2-D heat flow problem
 - Neglect conduction along top and bottom
 - Temperature does not vary in z
- > Interested in dominant time constant

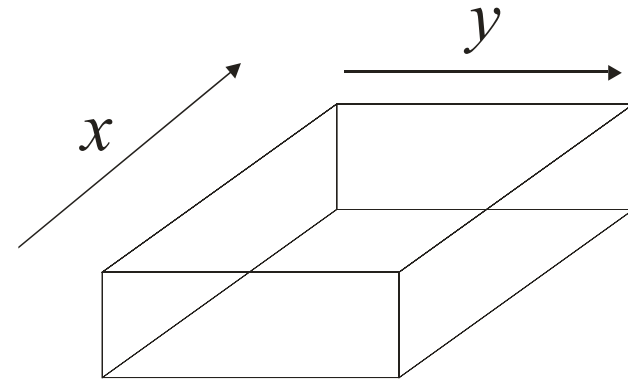

Eigenfunction expansion solution to heat-flow eqn.

$$T(x, y, t) = \sum_n \sum_m A_{n,m} \cos\left(\frac{n\pi x}{L}\right) \cos\left(\frac{m\pi y}{L}\right) e^{-\alpha_{m,n}t}$$

$$T_1(x, y, t) = A_1 \cos\left(\frac{\pi x}{L}\right) \cos\left(\frac{\pi y}{L}\right) e^{-\alpha_1 t}$$

Lowest mode

$$\tau_f = \frac{1}{\alpha_1} = \frac{L^2}{2\pi^2 D} = \frac{L^2 \tilde{C}_m \rho_m}{2\pi^2 \kappa}$$

Thermal modeling – batch system

> Obtain lumped heat capacity by weighing over mode volume

$$C_f = \rho_m \tilde{C}_m \int_{-L/2}^{L/2} \int_{-L/2}^{L/2} \int_0^H \cos\left(\frac{\pi x}{L}\right) \cos\left(\frac{\pi y}{L}\right) dx dy dz$$

> Extract thermal resistance from time constant

$$C_f = \rho_m \tilde{C}_m \frac{2L}{\pi} \frac{2L}{\pi} H$$

$$C_f = \frac{4\rho_m \tilde{C}_m L^2 H}{\pi^2}$$

> Thermal resistance same as zeroth-order model suggests

$$\tau_f = R_f C_f \Rightarrow R_f = \frac{1}{8\kappa H}$$

$$R_f = \frac{1}{\kappa} \frac{\text{length} \cdot \frac{1}{4}}{\text{area}} = \frac{L/2 \cdot \frac{1}{4}}{\kappa L H} = \frac{1}{8\kappa H}$$

> For $L=2$ mm, $\tau=1.4$ s

> $H=400$ μm , volume = 2 μl

Thermal modeling – batch system

- > Lumped elements for beams
 - Include beam capacitance
- > Two circuits to model beams
 - Capacitor in center
 - Capacitor at edge
- > Both circuits contain same energy in capacitor at steady state
 - Capacitor at edge is simpler

$$R_b = \frac{1}{4} \frac{1}{\kappa} \frac{\text{length}}{\text{area}}$$

$$C_b = \rho_m \tilde{C}_m \text{volume}$$

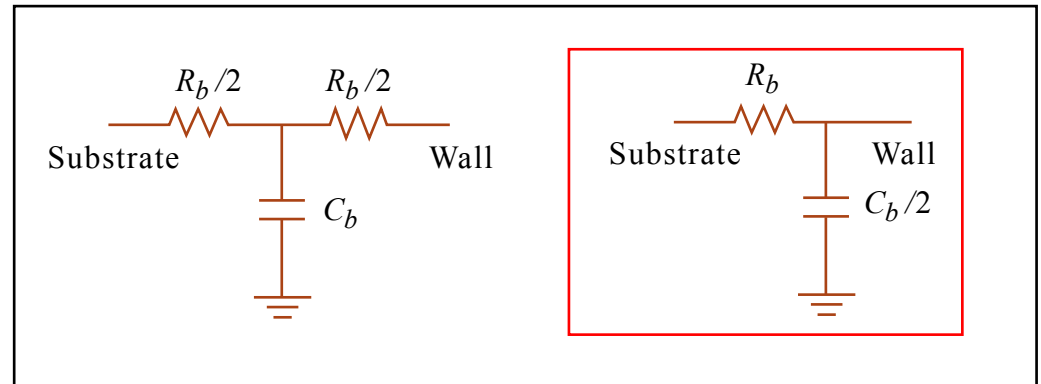
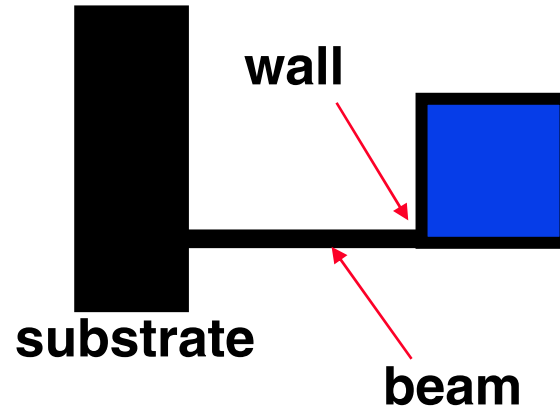

Image by MIT OpenCourseWare.

Adapted from Figure 22.14 in Senturia, Stephen D. *Microsystem Design*. Boston, MA: Kluwer Academic Publishers, 2001, p. 617. ISBN: 9780792372462.

Thermal modeling – batch system

- > Lumped circuit model of reactor
- > First-order lag between wall and fluid temperature

$$T_f = \frac{1}{1 + \tau_f s} T_w$$

$$\tau_f = \frac{L^2}{2\pi^2 D}$$

- > Making L smaller reduces lag

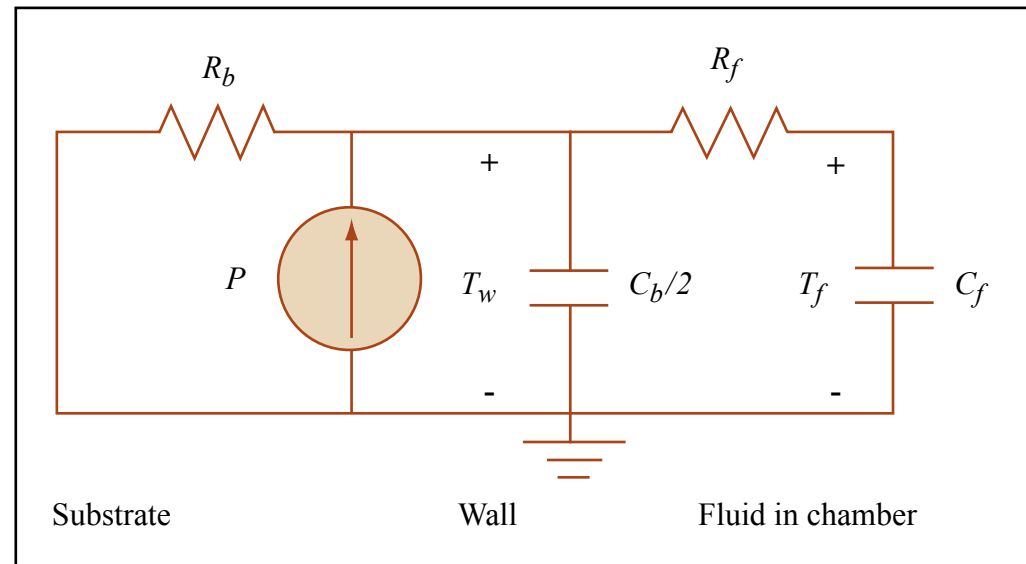
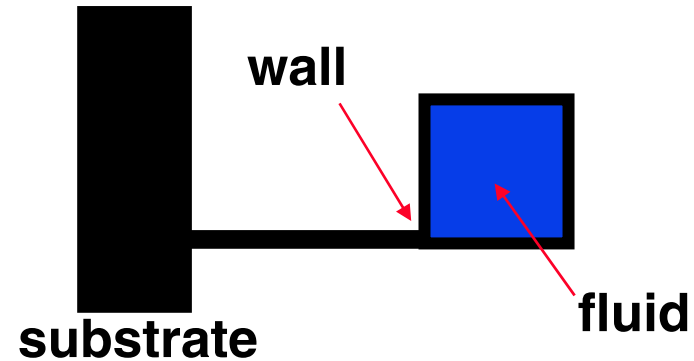

Image by MIT OpenCourseWare.

Adapted from Figure 22.15 in Senturia, Stephen D. *Microsystem Design*. Boston, MA: Kluwer Academic Publishers, 2001, p. 618. ISBN: 9780792372462.

Thermal modeling – batch system

- > Simulink proportional control circuit
- > Saturation needed for maximum +/- voltage swing
 - Set to 0 to 15 V

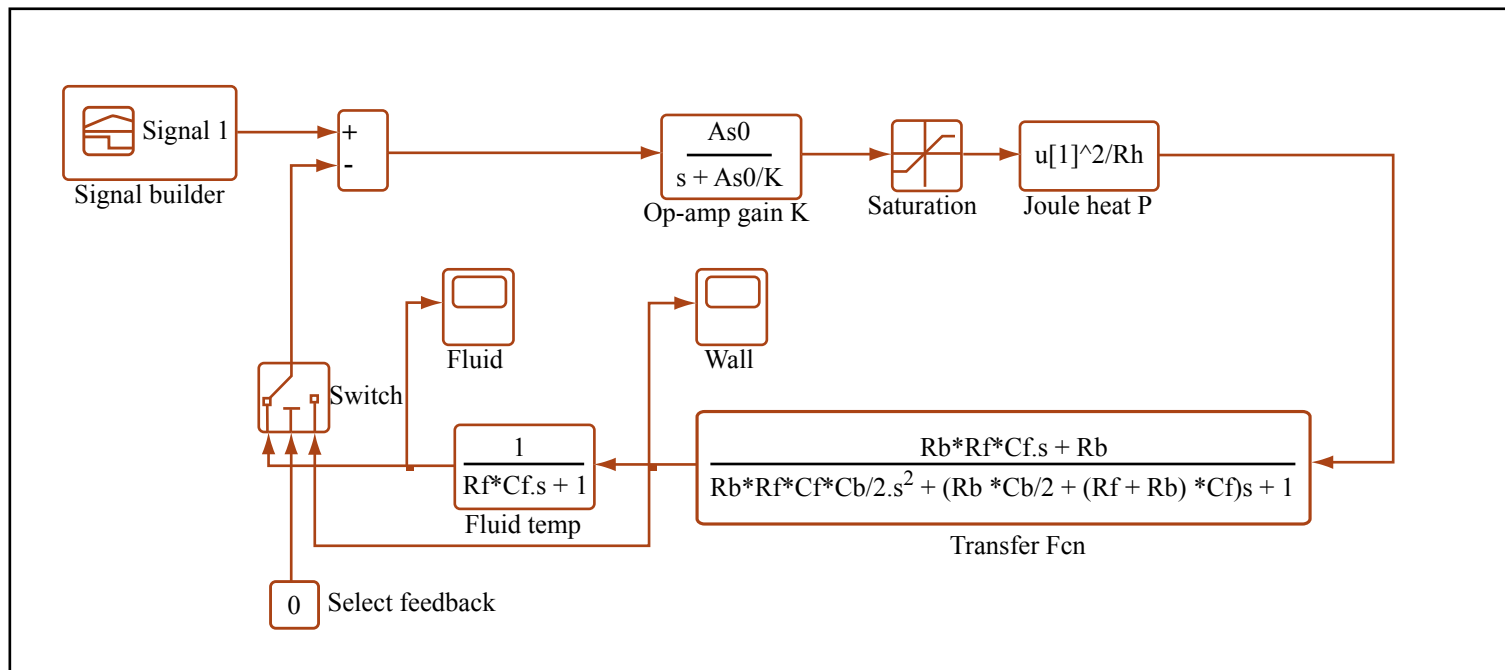

Image by MIT OpenCourseWare.

Adapted from Figure 22.16 in Senturia, Stephen D. *Microsystem Design*. Boston, MA: Kluwer Academic Publishers, 2001, p. 619. ISBN: 9780792372462.

Simulation response

- > Wall temperature can be controlled very quickly
- > Wall to fluid heat transfer limits performance
- > Sensing fluid temperature marginally reduces response times
 - But creates high-temp regions at chamber wall

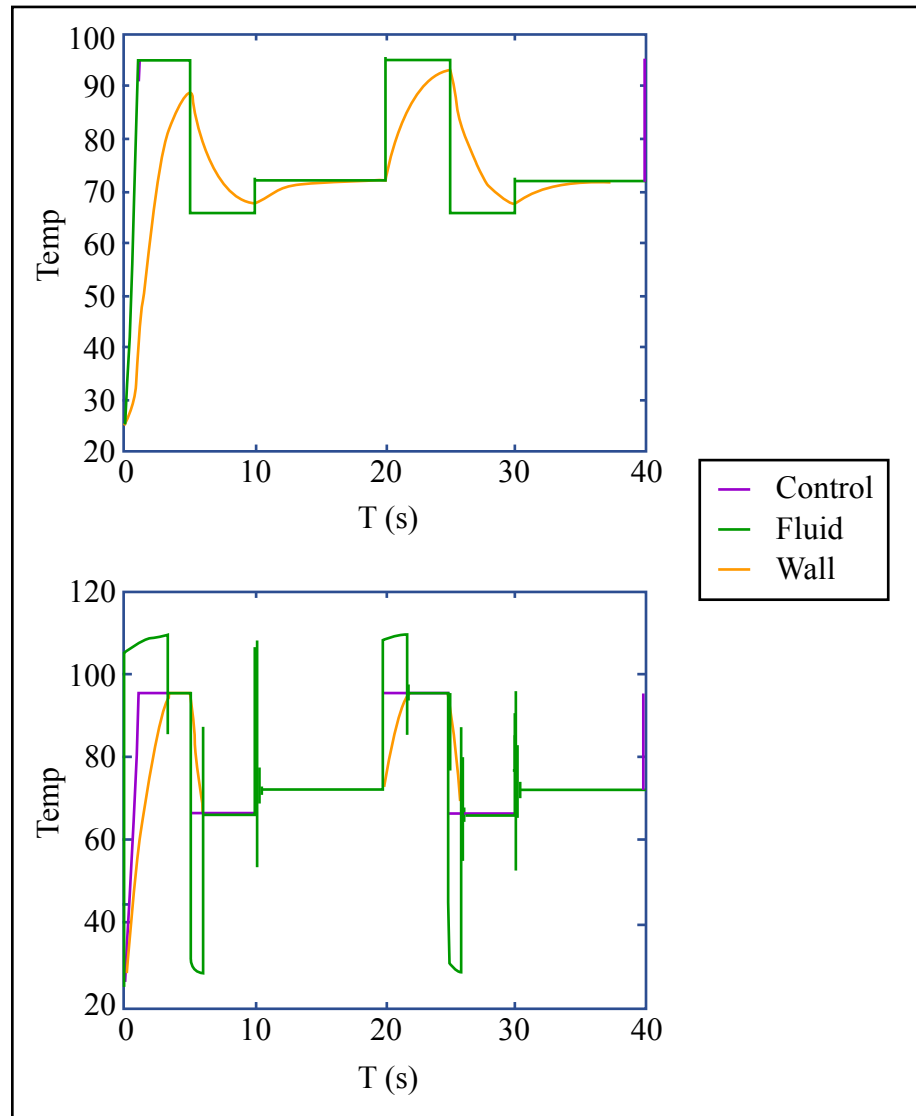

Image by MIT OpenCourseWare.

Adapted from Figure 22.17 in Senturia, Stephen D. *Microsystem Design*. Boston, MA: Kluwer Academic Publishers, 2001, p. 620. ISBN: 9780792372462.

Continuous-flow device

- > System partitioning: put heaters off-chip
- > Etch channels in glass, bond glass cover

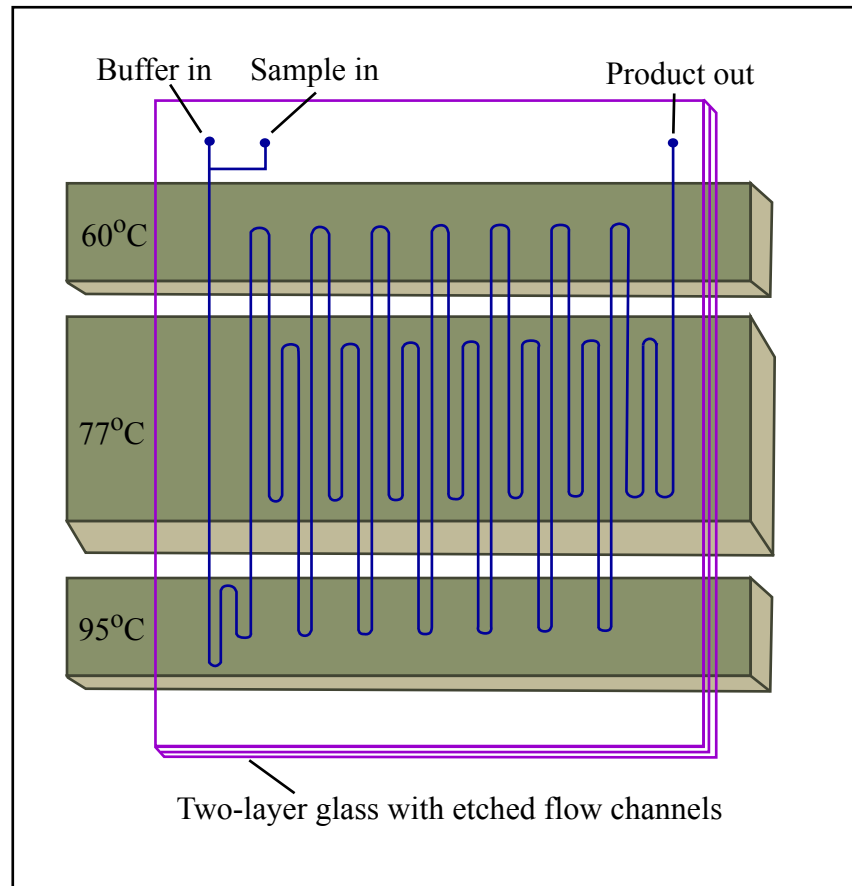

Image by MIT OpenCourseWare.

Adapted from Figure 1 on p. 1046 in Kopp, M. U., A. J. de Mello, and A. Manz.
"Chemical Amplification: Continuous-flow PCR on a Chip." *Science, New Series*
280, no. 5366 (May 15, 1998): 1046-1048.

Thermal model of continuous-flow device

> Wall-to-fluid time constant is same as in batch device

> $L_1=40 \mu\text{m}$, $L_2=90 \mu\text{m}$

> $D=1.4 \times 10^{-7} \text{ m}^2/\text{s}$

> $\tau_f=1.2 \text{ ms}$

> **1000× faster than batch device!**

$$\tau_f = \frac{L_1 L_2}{2\pi^2 D}$$

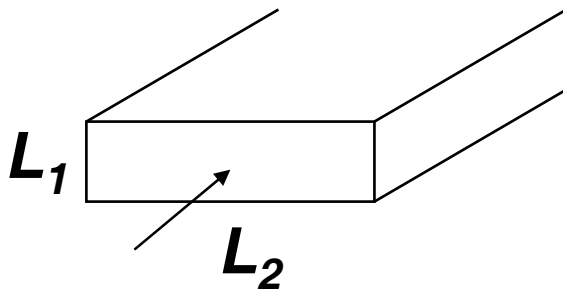

> Entrance length for thermal equilibration

$$L_e \approx 3v_f \tau_f$$

> Average flow velocity

$$v_f = \frac{Q_f}{\text{area}} = 20 \text{ mm/s}$$

$$L_e \approx 60 \mu\text{m}$$

This is much smaller than zone lengths

> Thermal Pe number is $\sim 10^{-3}$

Continuous-flow device

> What about Taylor dispersion?

> Pressure-driven may cause multiple samples to coalesce

> Hydrodynamic radius of 1 kb DNA ~ 50 nm

> Dispersivity is dominated by convection

- Samples will spread out a lot, limiting usefulness for multiple samples

$$D = \frac{k_B T}{6\pi\eta R}$$

$$Pe = \frac{LU}{D} = \frac{(40\mu m)(0.02m/s)}{4.4 \times 10^{-8} cm^2/s} \sim 2 \times 10^5$$

$$K = D \left(1 + \frac{Pe^2}{210} \right) f \left(\frac{L_1}{L_2} \right)$$

$$\frac{L_1}{L_2} \sim 0.4 \rightarrow f \left(\frac{L_1}{L_2} \right) = 4$$

$$K \sim 8 \times 10^8 \cdot D \sim 35 cm^2/s$$

Thermal lessons

- > Wall temperature in most microsystems can be quickly controlled**
- > Limiting step is wall-to-fluid heat transfer**
- > Solution is to minimize fluid characteristic length for heat diffusion**

Detecting PCR products

- > **Speeding up amplification is only half the battle...**
- > **DNA is not normally visible**
- > **In conventional PCR, detect products by separating stained DNA using electrophoresis in gel sieving matrix**
 - **This can take 0.5-2 hrs**

Image removed due to copyright restrictions.
Loading gel in electrophoresis apparatus.

Image removed due to copyright restrictions.
Photograph of an illuminated gel after electrophoresis.

Detecting PCR products

> Newer techniques allow real-time detection

- “Real-time PCR”

> Integrate illumination/detection optics, thermal cycler, and chemistry

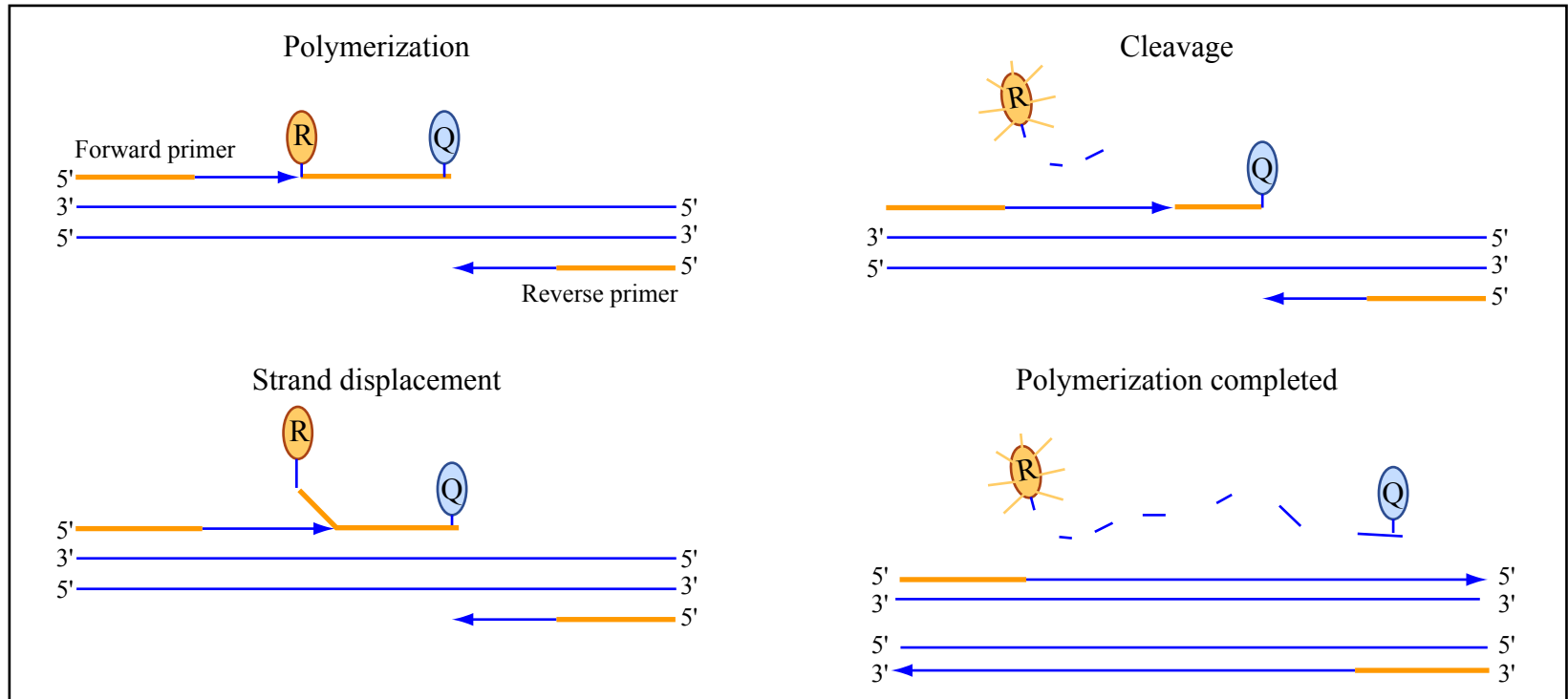

Image by MIT OpenCourseWare.

ABI Taqman assay

Detecting PCR products

- > Real-time thermocycler
- > 1.5 mm-wide capillaries
- > $\tau \sim 2\text{-}3$ sec up and down

Roche LightCycler

Images removed due to copyright restrictions.
Schematic of the thermal chamber for the LightCycler(R) 2.0.

Comparison of two microfluidic PCR approaches

Continuous flow	Batch
Faster thermal response	Slower
No temp overshoot	Depends on control system
Static protocol	Can change protocol easily
Taylor dispersion effects, and sample carryover	Sample carryover only
Optical detection more complicated	Simpler optical detection

Materials issues

- > **Reactor surface must be compatible with PCR reagents**
 - DNA, nucleoside triphosphates, polymerase, buffers
- > **Decreasing length scale and increasing SA/V hurts here**
 - More molecules start to interact with surface
- > **Bare Si or SiN inhibits PCR**
 - Probably due to denaturing of polymerase at surface
 - Silanizing or depositing/growing SiO₂ helps
 - Add carrier protein (e.g., BSA) to “block” surface
- > **Kopp uses glass, silanization, surfactant, and buffer!**
- > **Northrup use deposited SiO₂ plus BSA**

Outline

- > **What is hard about BioMEMS**
- > **BioMEMS success stories**
- > **DNA amplification and PCR**
- > **Two designs**
 - **A static PCR thermocycler**
 - **A flow-thru design**
 - **Comparison**
- > **Design evolution of static approach**
- > **Conclusions**

Evolution of chamber device

> Initial device introduced in 1993

> 1995-6

- Two-heater chambers
- Improved surface coating: silanize+BSA+polypro insert
- Fan for cooling
- Chamber volume 20 μl
- 30 sec cycle time
- ~ 10 $^{\circ}\text{C/s}$ up, 2.5 $^{\circ}\text{C/s}$ down
- “Real time”-PCR via coupled electrophoresis
- Cepheid formed

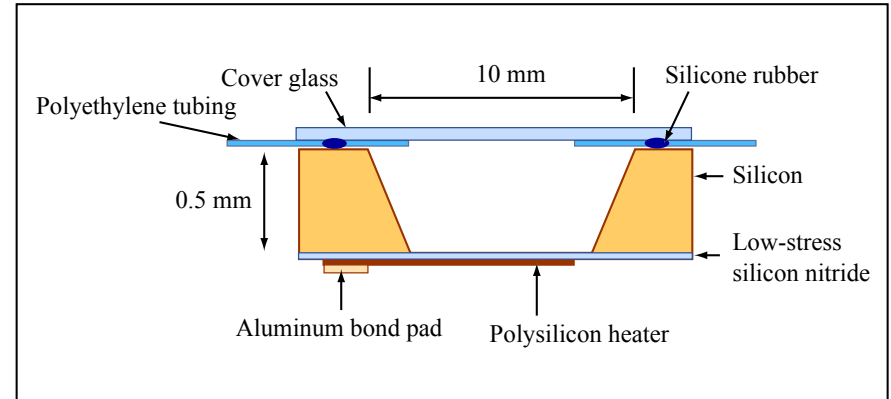

Image by MIT OpenCourseWare.

Adapted from Northrup, M. A., M. T. Ching, R. M. White, and R. T. Watson. "DNA Amplification with a Microfabricated Reaction Chamber." In *Transducers '93: the 7th International Conference on Solid-State Sensors and Actuators: digest of technical papers: June 7-10, 1993, PACIFICO, Yokohama, Japan*. Japan: Hiroyuki Fujita, 1993, p. 924-926. ISBN: 9784990024727.

Image removed due to copyright restrictions.

Image removed due to copyright restrictions.

Evolution of chamber device

- > **1998**
- > **Same two-heater chambers**
- > **Portable application**
- > **Up to 30 °C/s up, 4 °C/s down**
- > **17 sec minimum cycle time**
- > **Usually use 35+ sec**

Image removed due to copyright restrictions.

Evolution of chamber device

- > 2001 to present
- > Abandoned Silicon → Move to plastic and NOT microfabricated
- > Tubes are disposable thin-wall (50 μm) plastic that expands upon introduction
- > Tube is flat to decrease thermal response
- > ~30 sec cycle time
- > Ceramic chamber with thin film heater
- > Thermistor temp sensor

Image by MIT OpenCourseWare.

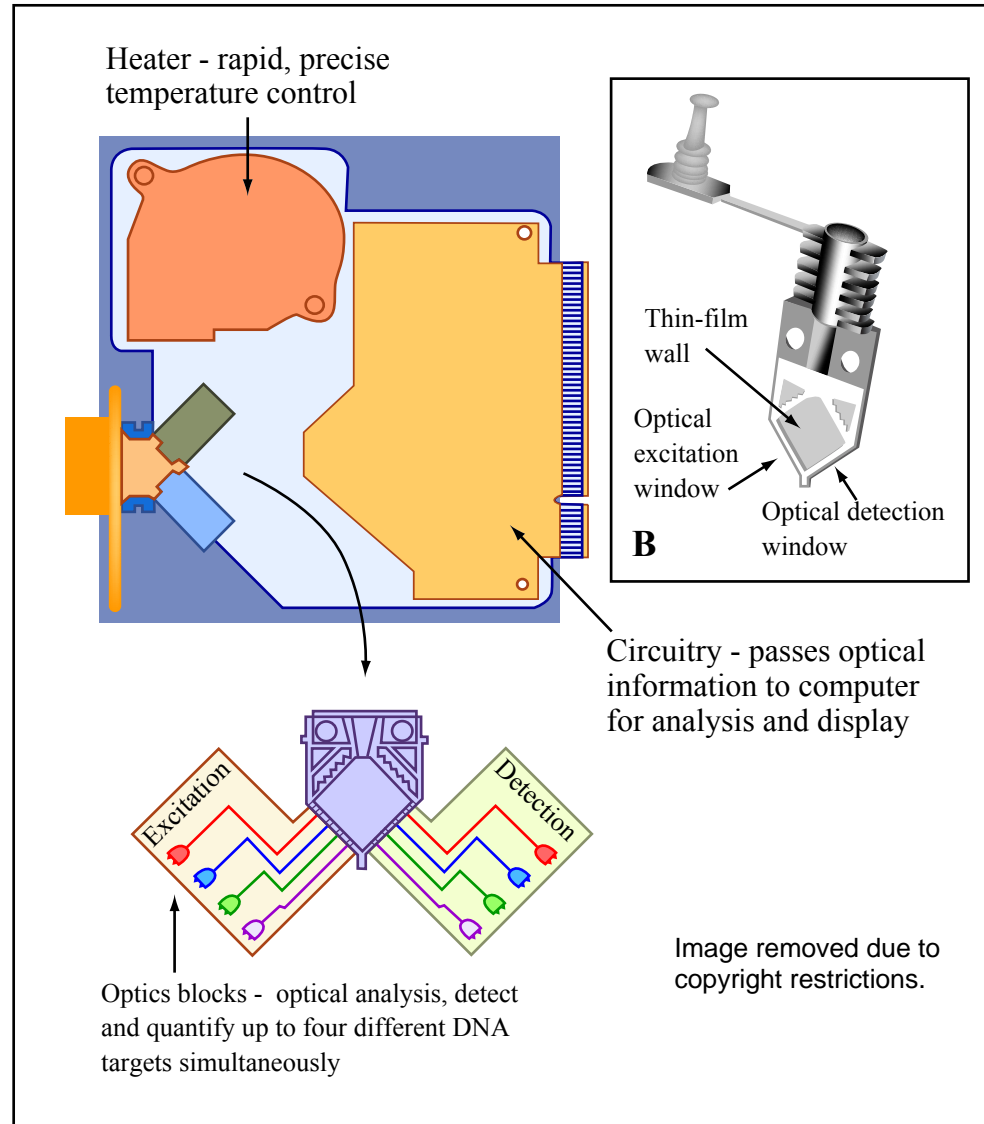

Conclusions

- > **BioMEMS commercial successes are still not here**
- > **Designing the engineered part is often routine**
- > **Interfacing with biology is where it gets hard**
- > **Sometimes the right solution is to NOT microfab**